

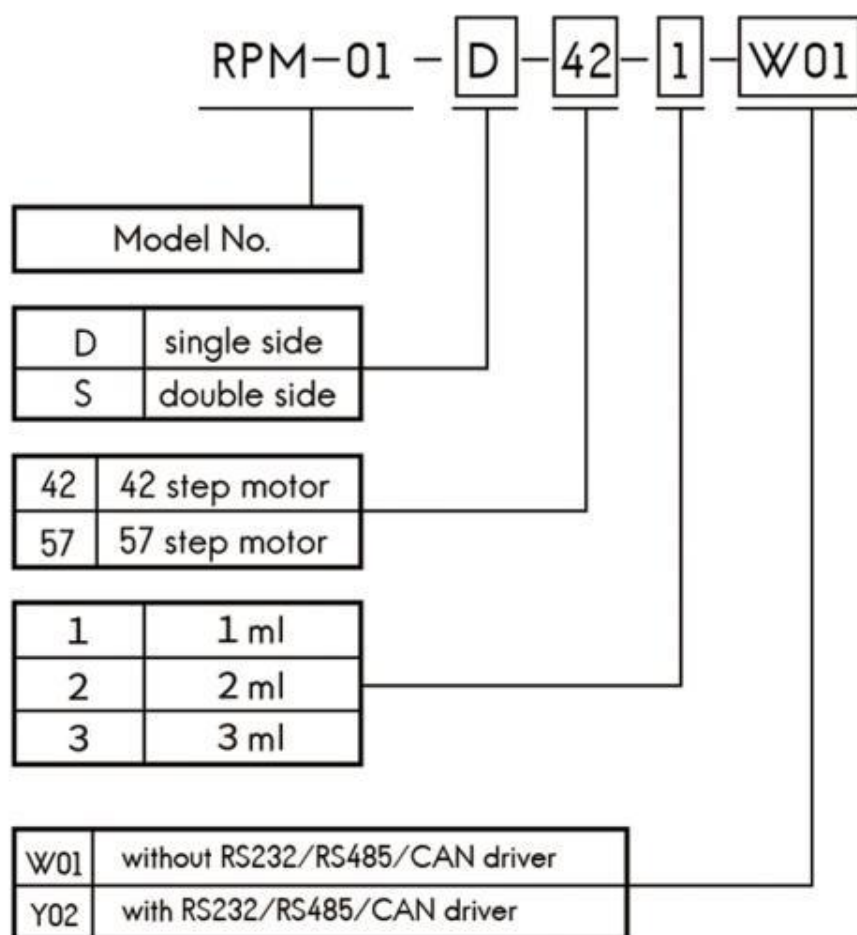

Model Number



Dimension (unit: mm)



Rpm-01-D-42-W.PDF



Rpm-01-D-42-Y.PDF



Rpm-01-S-57-W.PDF



Rpm-01-S-57-Y.PDF

Pump Structure

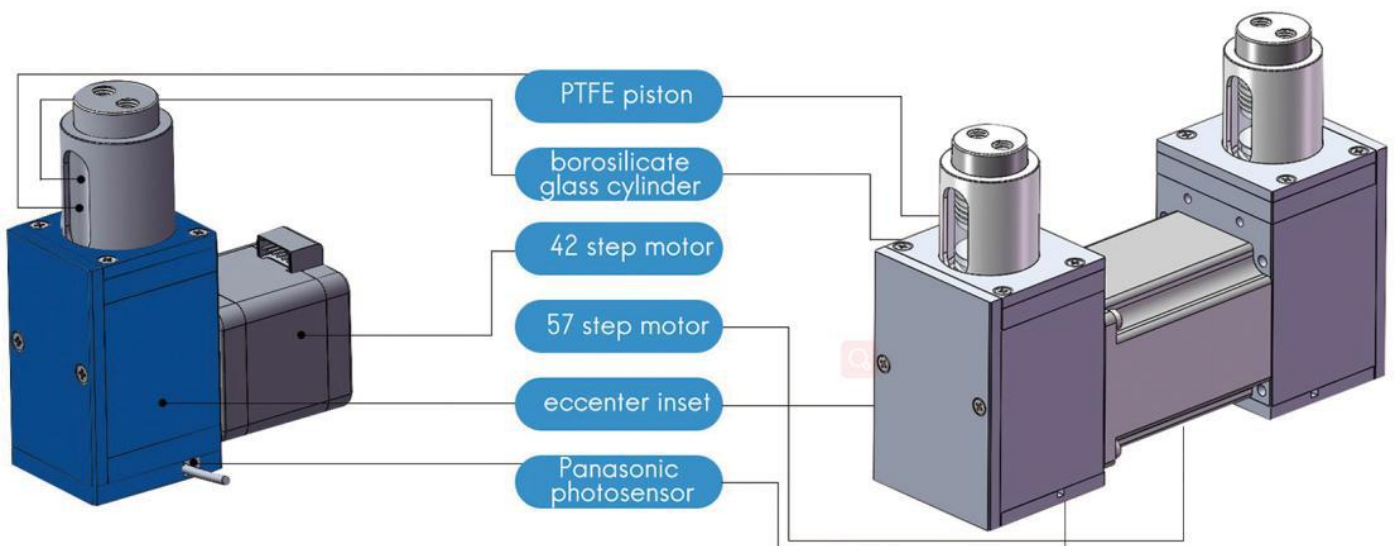

Technical Parameters

Model No.	Rpm-01-D (single side) Rpm-01-S (double side)		
Function of Rpm-01	Instead of peristaltic pumps		
Working Feature	High Precision Constant Liquid Dosing		
Accuracy	±1% @ 100% reciprocating stroke		
Repeatability	3‰ - 7‰ (0.3% - 0.7%)		
Pressure rating	Maximum 0.3Mpa (media: water)		
Service life	3 million times no leakage (media: water)		
Function of Optocoupler	Upper and nether Optocoupler to protect the pump from being damaging		
Actuator	Eccenter		
Syringe Volume	1ml	2ml	3ml
Resolution	1ml (single side) 2ml (double side)	2ml (single side) 4ml (double side)	3ml (single side) 6ml (double side)
Motor Speed	Min.1rpm Max.120rpm (single side) Min.1rpm Max.150rpm (double side)		
Fluid path	Borosilicate glass, PTFE		
Connection	1/4-28UNF Female		
Communication	RS232/RS485/CAN		
Baud rate	RS232/RS485: 9600dps, 19200dps, 38400dps, 57600dps, 115200dps CAN: 100Kbps, 200Kbps, 500Kbps, 1Mbps		
Device address & Parameter setting	Communication interface		
Power supply	DC24V/1.5A		
Working environment	5°C– 55°C < 80% relative humidity, non-condensing		

Dimension (L*W*H)	98.3*42*116.4mm (single side) 181.6*56*125.08mm (double side)
Net Weight (kg)	0.8kg (single side) 2.158kg (double side)

Flow Rate Table

Rpm-01-D (single side)					
Speed	1rpm	2rpm	3rpm	120rpm
1ml Flow Rate	1ml/min	2ml/min	3ml/min	120ml/min
2ml Flow Rate	2ml/min	4ml/min	6ml/min	240ml/min
3ml Flow Rate	3ml/min	6ml/min	9ml/min	360ml/min
Rpm-01-S (double side)					
Speed	1rpm	2rpm	3rpm	120rpm
1ml Flow Rate	2ml/min	4ml/min	6ml/min	240ml/min
2ml Flow Rate	4ml/min	8ml/min	12ml/min	480ml/min
3ml Flow Rate	6ml/min	12ml/min	18ml/min	720ml/min

Motor Specification



0.9° 42 Stepper Motor.pdf

Motor Wire	42 0.9°step motor	57 1.8°step motor
A+	Orange	Orange
A-	Blue	Blue
B+	Red	Red
B-	Yellow	Yellow

Motor Parameter	42 0.9°step motor	57 1.8°step motor
Max. power	9.2W	18.8W
Step angle	0.9°	1.8°
Phase	2	2
Phase voltage	4.2V	4.0V
Phase current	1.1A	2.35A
Resistance	3.8Ω±0.38	1.7Ω±0.17
Inductance	5.2mH REF	7mH REF
Insulation	100m Ω MIN	100m Ω MIN
Max. Temperature	80°C MAX	80°C MAX
Explosion-Proof level	B	B

Driver Port (Rpm-01 with driver)

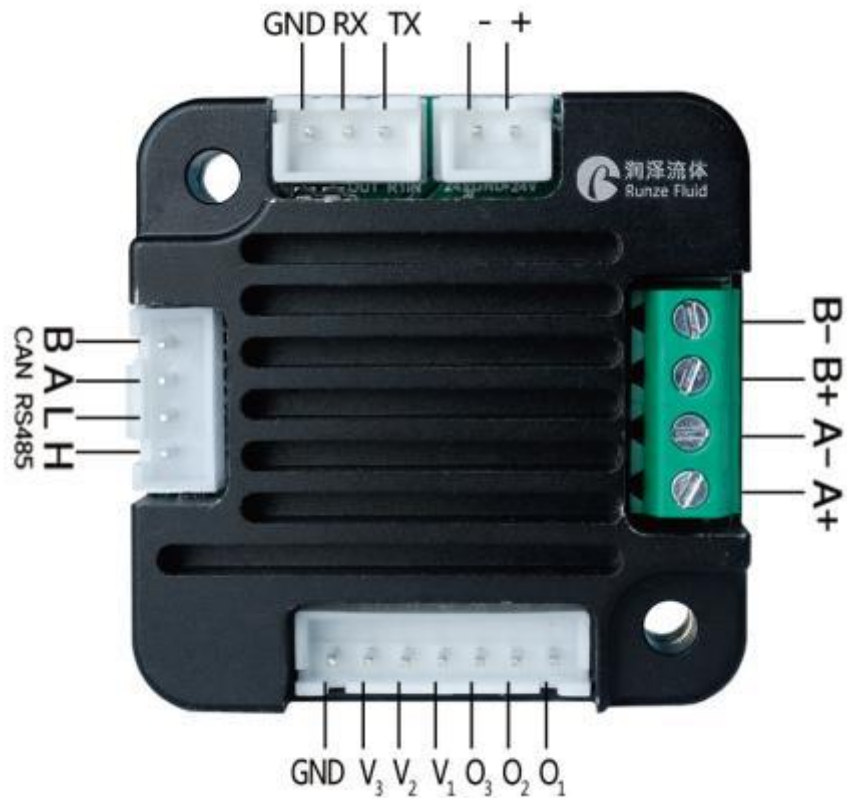

Port Name	Description	Port Name	Description
+	DC24V positive	A+/A-	Phase A wiring
-	DC24V negative	B+/B-	Phase B wiring
TX	RS232 TX	O1	Optocoupler wiring
RX	RS232 RX	O2	
GND	GND	O3	
H	CAN H	V1	
L	CAN L	V2	
A	RS485 A	V3	
B	RS485 B	GND	

Accessories (Rpm-01 with driver)



RS232/RS485 Converter



Power Supply



U disk with debug software

Driver Control Instruction

The data between syringe pump and upper monitor (PC, PLC, Raspberry Pi, micro-controller) was transmitted by serial communication RS232/RS485/CAN

Communication Form: Asynchronous serial communication; Command and data frames are sum check 2 Byte; Commands and data are hexadecimal numbers; Command parameters saved by little-endian mode.

Communication Interface: RS232 or RS485 or CAN

Communication Mode: Bidirectional asynchronous; master-slave mode

Baud rate: 9600bps,19200bps,38400bps,57600bps,115200bps (RS232/RS485) / 100K, 200K, 500K, 1M (CAN)

Data bit: 8

Even-odd Check: None

Response Time: <1 second

1. Command List

Setting Command

Command code	Function	Command Type	Number of Bytes
0x00	Address setting	Factory command	4
0x01	RS232 baud rate setting	Factory command	4
0x02	RS485 baud rate setting	Factory command	4
0x03	CAN baud rate setting	Factory command	4
0x05	Motor subdivision setting	Factory command	4
0x07	Maximum speed setting	Factory command	4
0x0e	Setting auto-reset when power on	Factory command	4
0x10	CAN destination address setting	Factory command	4

Query Command

Command code	Function	Command Type	Number of Bytes
0x20	Query address	Common command	2
0x21	Query RS232 baud rate	Common command	2
0x22	Query RS485 baud rate	Common command	2
0x23	Query CAN baud rate	Common command	2
0x25	Query motor subdivision	Common command	2
0x27	Query maximum speed	Common command	2
0x2e	Query auto reset when power on	Common command	2
0x30	Query CAN destination address	Common command	2
0x3f	Query current version	Common command	2

Control Command

Command code	Function	Command Type	Number of Bytes
0x46	Motor CW rotates specified circles as CW, motor stops when touch reset	Common command	2

	Optocoupler.		
0x47	Motor CW rotates constantly	Common command	2
0x48	Motor CCW rotates constantly	Common command	2
0x49	Strong stop	Common command	2
0x4a	Query motor status	Common command	2
0xff	Reset internal data of driver	Common command	2

Response Command

Code B2	Parameter Instruction
0x00	Normal status
0x01	Frame error
0x02	Parameter error
0x03	Optocoupler error
0x04	Motor busy
0x05	Motor stalling
0x06	Unknown position
0xfe	Task suspension
0xff	Unknown error

2. Control Command Format

“Common command” message frame is 8 bytes, full format as following:

Send Command (Common Command)

Send command	Start code	Address bit	Control command	Command parameter	End code	Sum check
Byte code	B0	B1	B2	B3, B4	B5	B6, B7
Number of Bytes	1	1	1	2	1	2

“Factory Command” message frame is 14 bytes, full format as following:

Send Command (Factory Command)

Send command	Start code	Address bit	Control command	Password	Command parameter	End code	Sum check
Byte code	B0	B1	B2	B3/B4/ B5/B6	B7/B8/ B9/B10	B11	B12/B13
Number of Bytes	1	1	1	4	4	1	2

Response Command (Common Command)

Response command	Start code	Address bit	Response state	Response parameter	End code	Sum check
Byte code	B0	B1	B2	B3, B4	B5	B6, B7
Number of Bytes	1	1	1	2	1	2

Definition	Code
Start code B0	0xCC
End code B5 (B11)	0xDD

Note: start code of common command and factory command are B0; end code of common command is B5 while end code of factory command is B11.

Name	Abbreviation	Code B1	Remark
Address bit	address	0XX	

- Note:** 1. Send command and response command share the same address bit
 2. XX in the "0XX" means settable, factory defaults as 0x00, parameter range as 0x00 ~ 0xFF.

Control Command (Factory Command) (B2~B10)

Code B2	Abbreviation	Password B3 B4 B5 B6	Parameter B7 B8 B9 B10 Instruction
0x00	Address setting	B3=0xFF B4=0xEE B5=0xBB B6=0xAA	B7=0XX (B8=0x00 B9=0x00 B10=0x00) XX value range is 00 ~ FF, defaults as 00
0x01	RS232 baud rate setting	B3=0xFF B4=0xEE B5=0xBB B6=0xAA	Total 5 baud rates: factory defaults as 9600bps (B8=0x00 B9=0x00 B10=0x00)
0x02	RS485 baud rate setting	B3=0xFF B4=0xEE B5=0xBB B6=0xAA	B7=0x00 baud rate as 9600bps B7=0x01 baud rate as 19200bps B7=0x02 baud rate as 38400bps B7=0x03 baud rate as 57600bps B7=0x04 baud rate as 115200bps
0x03	CAN baud rate setting	B3=0xFF B4=0xEE B5=0xBB B6=0xAA	Total 4 baud rates: factory defaults as 100K (B8=0x00 B9=0x00 B10=0x00) B7=0x00 baud rate as 100K B7=0x01 baud rate as 200K B7=0x02 baud rate as 500K B7=0x03 baud rate as 1M
0x05	Motor subdivision setting	B3=0xFF B4=0xEE B5=0xBB B6=0xAA	共 9 种细分: (B8=0x00 B9=0x00 B10=0x00) B7=0x00 No motor subdivision (1) B7=0x01 Motor subdivision 2 B7=0x02 Motor subdivision 4

			B7=0x03 Motor subdivision 8 B7=0x04 Motor subdivision 16 B7=0x05 Motor subdivision 32 B7=0x06 Motor subdivision 64 B7=0x07 Motor subdivision 128 B7=0x08 Motor subdivision 256
0x07	Maximum speed setting	B3=0xFF B4=0xEE B5=0xBB B6=0xAA	B7=0xXX B8=0xXX B9=0x00 B10=0x00 B8B7 value range is 0x0005 ~ 0x015E, Speed set as 5~350rpm (factory default speed 100rpm, that is B7=64) Note: speed range 5~350rpm is best working speed recommended, pump may works wrongly when lower than 5rpm or higher than 350rpm.
0x0e	Setting automatic reset when power on	B3=0xFF B4=0xEE B5=0xBB B6=0xAA	(B8=0x00 B9=0x00 B10=0x00) B7=0x00 non-automatic reset B7=0x01 automatic reset
0x10	Setting CAN destination address	B3=0xFF B4=0xEE B5=0xBB B6=0xAA	B7=0xXX (B8=0x00 B9=0x00 B10=0x00) XX value range is 00 ~ FF, default as 00

Query Command (B2~B4)

Code B2	Abbreviation	Parameter Instruction B3 B4
0x20	Query address	B3=0x00 B4=0x00
0x21	Query RS232 baud rate	B3=0x00 B4=0x00
0x22	Query RS485 baud rate	B3=0x00 B4=0x00
0x23	Query CAN baud rate	B3=0x00 B4=0x00
0x27	Query maximum speed	B3=0x00 B4=0x00
0x2e	Query automatic reset when power on	B3=0x00 B4=0x00
0x30	Query CAN destination address	B3=0x00 B4=0x00
0x3f	Query current version	B3=0x00 B4=0x00

Control Command (B2~B4)

Command code	Function	Parameter B3 B4
0x46	Motor CW rotates specified circles as CW, motor stops when touch reset Optocoupler.	B3=0x00 B4=0x00 Motor stops when touch Optocoupler
0x47	Motor CW rotates constantly	B3=0x00 B4=0x00
0x48	Motor CCW rotates constantly	B3=0x00 B4=0x00
0x49	Strong stop	B3=0x00 B4=0x00
0x4a	Query motor status	B3=0x00 B4=0x00
0xff	Reset internal data of driver	B3=0x00 B4=0x00

Sum Check (B6, B7)

Name	Abbreviation	Code B6, B7	Remark
Sum check	Sum check	0xXX 0xXX	XX means sum from start code to end code

Note: Sum check bit of factory command is B12, B13; Sum check of common command is B6, B7.

Response Command

Code B2	Instruction	Other Parameter = B3 B4
0x00	Normal status	B3=0x00 B4=0x00
0x01	Frame error	Parameter=0x00 0x00,
0x02	Parameter error	Parameter=0x00 0x00
0x03	Optocoupler error	Parameter=0x00 0x00
0x04	Motor busy	Parameter=0x00 0x00
0xfe	Task suspend	Parameter=0x00 0x00
0xff	Unknown error	Parameter=0x00 0x00

- (1) Code B2 in response command means current motor status. Only when B2=0x00 motor works normally. Other codes means different motor breakdown.

When pump controlled by RS485 and send command B2=0x44 or 0x45, status parameter in response command is FE (task suspension), it means motor is now under working as command required, if send other commands now (except for query command), the status parameter in response command will be 04 which means motor busy, if resend polling command 0x4a, the status parameter in response command will be 00 which means motor is normally running). See below chart for ref.:

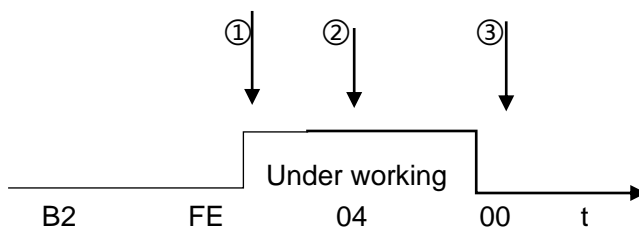

- ① send control command (B2=0x4d or 0x42, 0x45)
- ② send other control commands
- ③ send polling command 0x4a

- (2) Other parameters B3,B4 in response command make sense only when send inquiry command; when send setting or control command, response parameters make no sense with default 00 00. When send inquiry command and parameter B2 in response command is 00, then response B3, B4 make sense, returned value is the inquiry result. E.g. when sent inquiry command 0x21 (Inquiry RS232 baud rate), B3, B4 in response command is 04 00, it means baud rate of RS232 is 115200bps.

Kind Reminder:

All code parameters saved by little-endian mode. Little-endian mode means low data position saved in the low address, high data position saved in the high address.

3. Operation Examples (RS232)

1. Power on the device
2. Click "Factory mode" if necessary, or directly set the commands if unnecessary.
3. Restart the device after finish settings (24v power supply **MUST** be cut off before restart) to make it into effect.

E.g.1 Set maximum speed (200rpm)

1. Tick "factory mode" as picture 1
2. Input "00" into "Address" (default as 00, if address has been changed, then input new address), input speed code 07 into "Command", input speed C8 into "Parameter" (hexadecimal number), click "Send", it means correct settings if received code B3=C8.
3. After confirmed correct settings, cancel the ticked "Factory mode" as picture 2

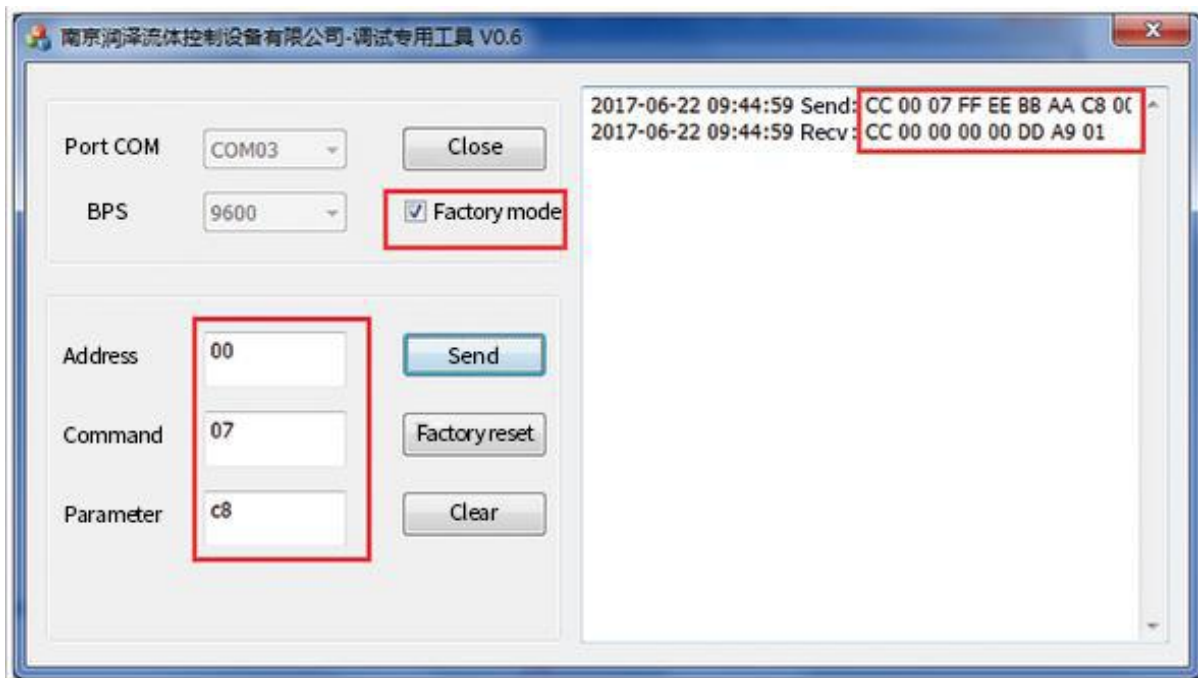

Picture 1

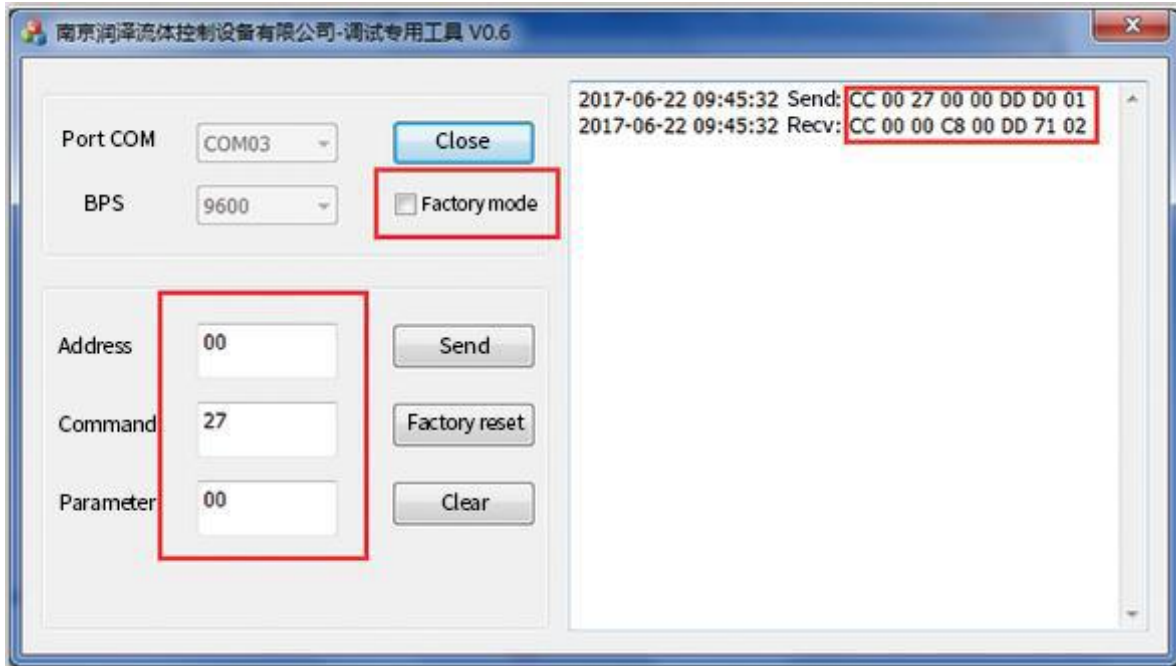

Picture 2

4. Query preset speed, input speed code 27 into “Command”, input “00” into “Parameter” (if you input other command, received parameter will be 02 which means parameter error), click “Send”, it means correct settings if received code as picture 2.
5. Restart the device after finish correct settings (24v power supply **MUST** be cut off before restart) to make the settings into effect.

Note: There are two ways of speed setting: Dynamically setting and Factory setting.

Dynamically setting no need to tick “Factory mode” and set speed will be invalid after used once, it is current working speed, if dynamically speed is not set, device default work at maximum speed. Speed set under “Factory Command” can be kept using.

E.g.2 Query Motor Status (Picture 3)

1. Input “00” into “Address” (If address has been changed, then input new address)
2. Input “4A” into “Command” (Query motor status)
3. Input “00” into “Parameter” (if you input other parameters, returned message will be 02 which means parameter error)
4. Click “Send” after finish inputs, motor status data will be received, it means correct settings if received code B3=00 as picture 3.

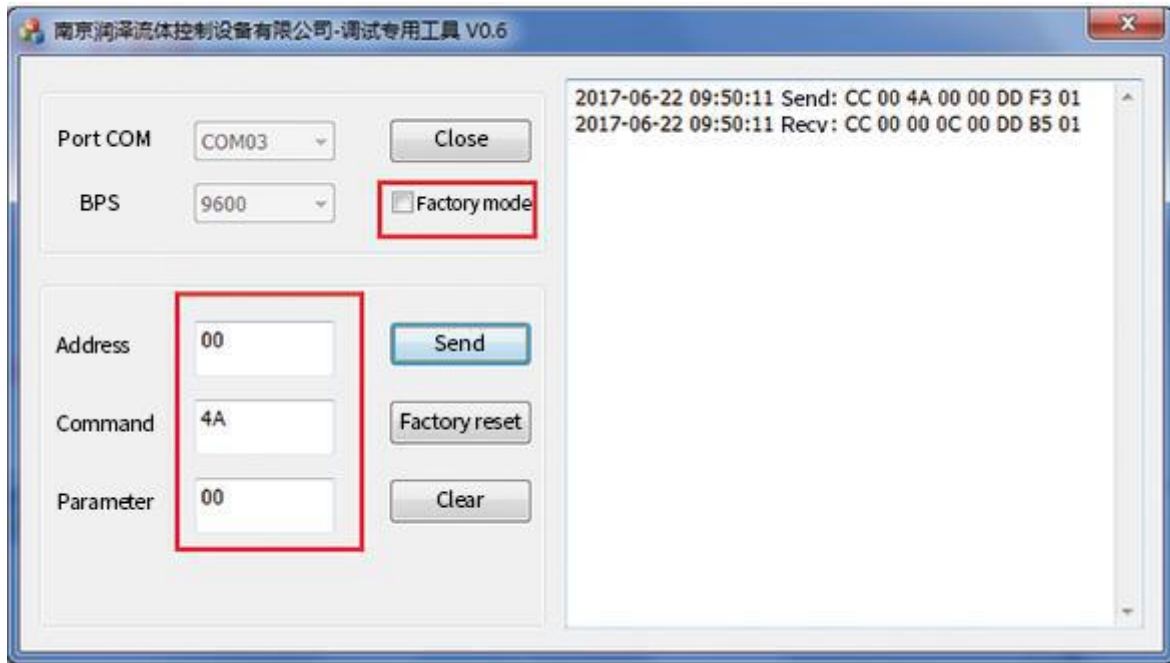

Picture 3

E.g.3 Control Syringe Pump Suction and Dispense Liquid

1. Input "00" into "Address" (if address has been changed, then input new address) and command "47 (48)" of motor CW (CCW) rotates into "Command" and command "00" into "Parameter", click "send", it means correct settings if received code as picture 4.



Picture 4

2. Input "00" into "Address" (if address has been changed, then input new address), input command 49 of strong stop into "Command" and input "00" into "Parameter" ,click "Send", it means correct settings if received code as Picture 5.

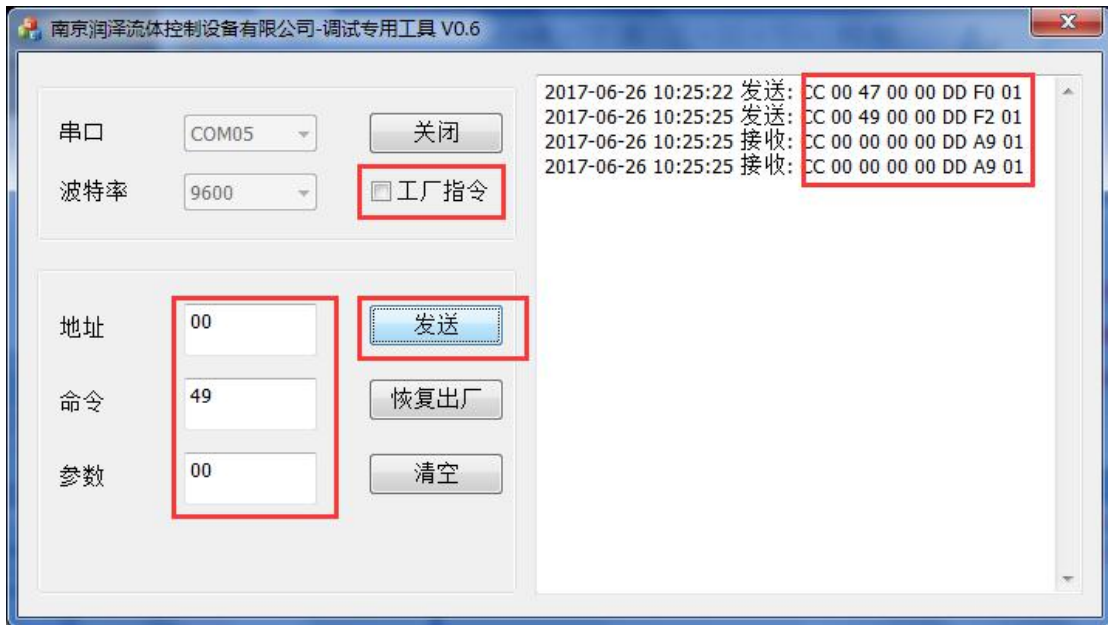

Picture 5

3. RS232 Debug Instructions

(1) RS232 Debug Tool: MotorTester V0.6.exe

Since no RS232 communication interface on computer, we need to realize the communication by USB. Select the correct COM port from Device Manager on Computer, you need to verify which COM port is the correct one if there are few COM ports.



Picture 7

In picture 8, baud rate is device factory default 9600bps, after select correct COM port and baud rate, input

correct command code B2 of Address, Command and Parameter, received parameter will be B3 B4. If you need to input factory command, then click “factory mode” while common command no need to click this blank. Click “Send”, the sent and received code will be shown in the right display box.



Picture 8

The button "clear" in debug tool means clear the contents in right display box; “factory reset” means to return all the settings to factory default settings. Address, command, parameter must be input hexadecimal numbers.

(2) RS232 communication example

① Send Command: Set RS232 baud rate

B0	B1	B2	B3/B4/B5/B6	B7/B8/B9/B10	B11	B12	B13
0xCC	0x00	0x01	B3=0xFF B4=0xEE B5=0xBB B6=0xAA	B7=0x04 B8=0x00 B9=0x00 B10=0x00	0xDD	0x00	0x05

Response Command

B0	B1	B2	B3	B4	B5	B6	B7
0xCC	0x00	0x00	0x00	0x00	0xDD	0xA9	0x01

RS232 baud rate setting is factory command, “factory mode” need to be ticked, operation result as picture 9:

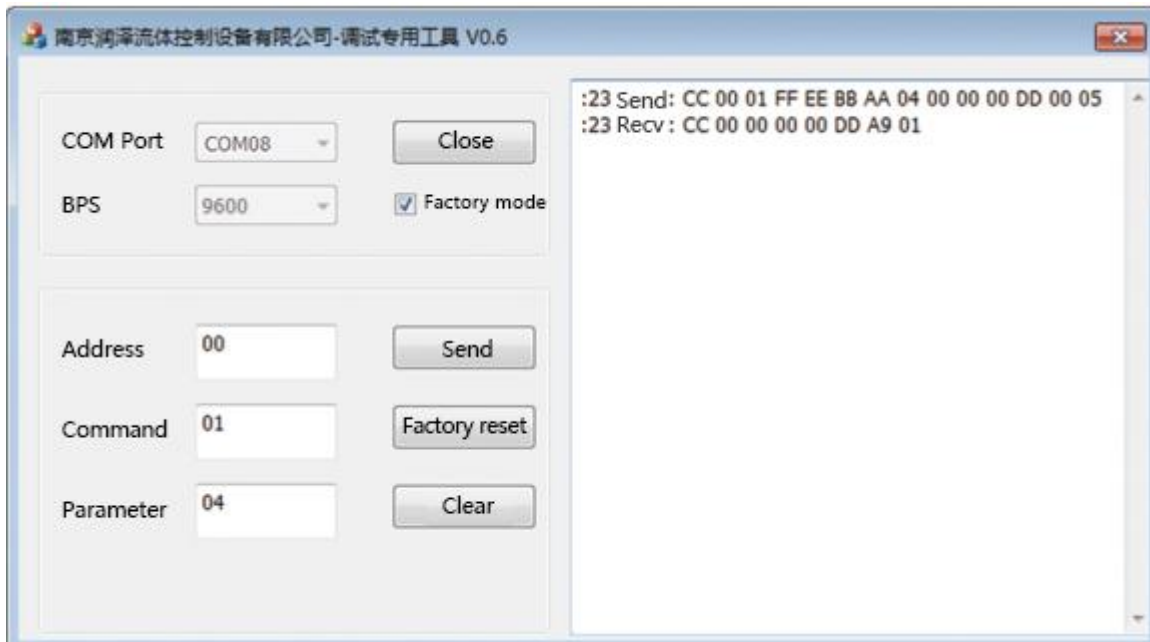

Picture 9

② Send Commands: Query reset speed

B0	B1	B2	B3	B4	B5	B6	B7
0xCC	0x00	0x2B	0x00	0x00	0xDD	0xD4	0x01

Response command

B0	B1	B2	B3	B4	B5	B6	B7
0xCC	0x00	0x00	0xC8	0x00	0xDD	0x71	0x01

Query command is common command, operation result as picture 10:

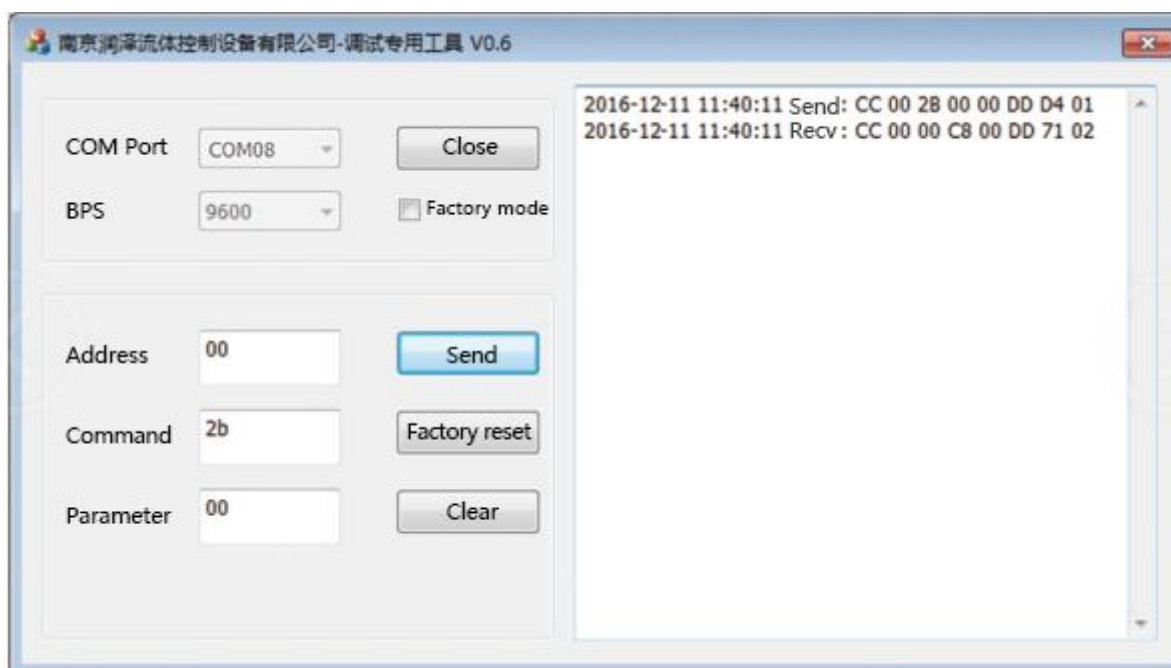

Picture 10

Parameter bit in response command is C8 00. Little-Endian storage with low data bit saved in low address bit, hexadecimal 0x00C8 converted to decimal is 200, so reset speed is 200rpm.

4. RS485 Debug Instructions

(1) RS485 Debug Tool: MotorTester V0.6.exe

① Send command: Query current motor status

B0	B1	B2	B3	B4	B5	B6	B7
0xCC	0x00	0x4a	0x00	0x00	0xDD	0xF3	0x01

Response command

B0	B1	B2	B3	B4	B5	B6	B7
0xCC	0x00	0x00	0x00	0x00	0xDD	0xA9	0x01

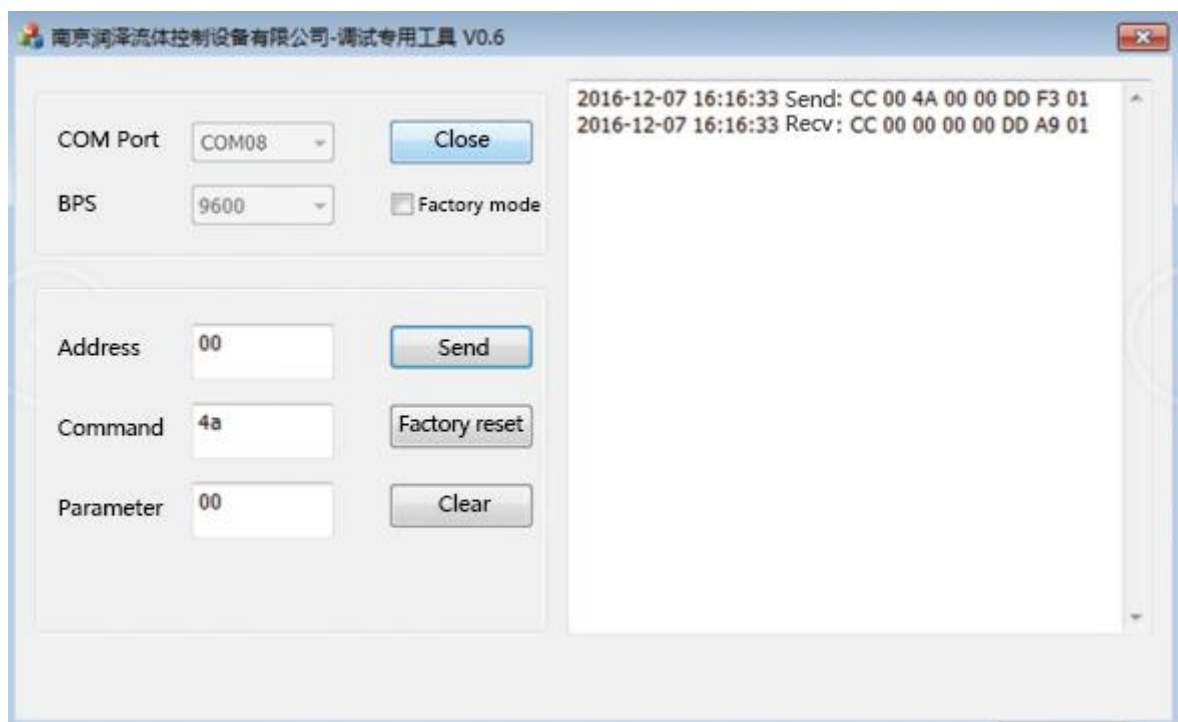

Picture 11

Note: When RS485 control several devices, 0x4a is polling command, each time control command B2=0X44 or 0X45 was sent out, you need to send polling command to inquiry current motor status, or when you send other commands (except for query command) it will show motor busy.

② Send Command: Reset

B0	B1	B2	B3	B4	B5	B6	B7
0xCC	0x00	0x45	0x00	0x00	0xDD	0xEE	0x01

Response command

B0	B1	B2	B3	B4	B5	B6	B7
0xCC	0x00	0xFE	0x00	0x00	0xDD	0xA7	0x02

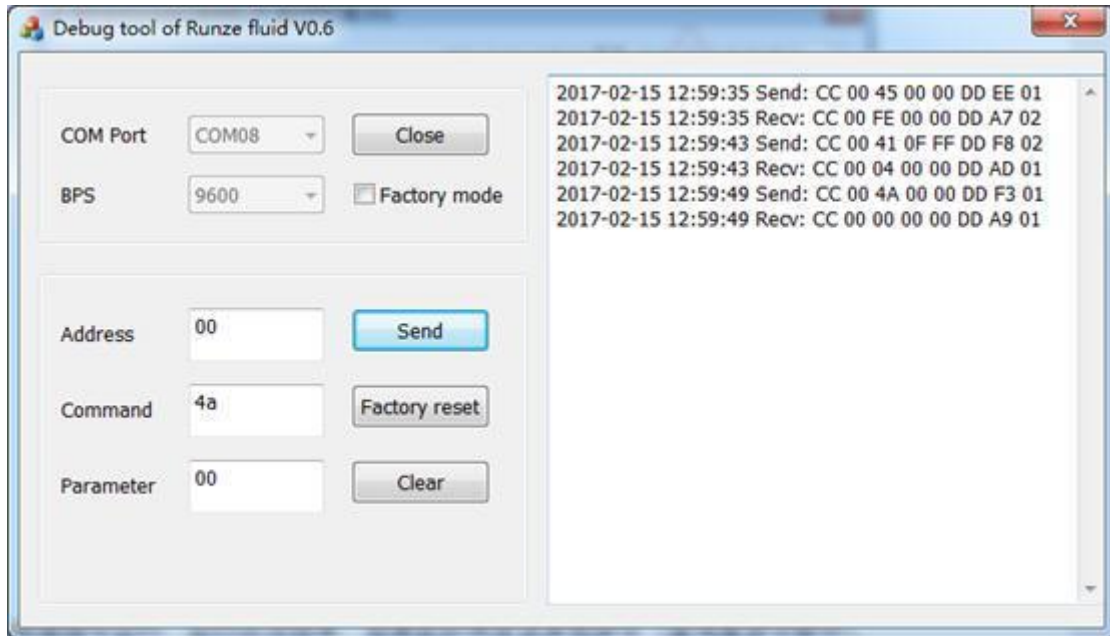

Picture 12

Status parameter B2=0XFE in response command means motor is working as sent commands, if send other commands (except for inquiry command) now, the status parameter in response command should be 04 (motor busy), if resend polling order 0x4a, the status parameter in response command should be 00 (motor works in normal state as picture12).

Note: When RS485 control several devices, 0x4a is polling command, each time control command B2=0X4d, 0x42 or 0X45 was sent out, you need to send polling command to query current motor status, or when you send other commands (except for inquiry command) it will show motor busy.

③ Send Command: Strong Stop

B0	B1	B2	B3	B4	B5	B6	B7
0xCC	0x00	0x49	0x00	0x00	0xDD	0XF2	0x01

Response Command

B0	B1	B2	B3	B4	B5	B6	B7
0xCC	0x00	0x00	0x00	0x00	0xDD	0xA9	0x01

Operation result as picture 13:



Picture 13

When pump controlled by RS485 and send command B2=0x44 or 0x45, status parameter in response command is FE (task suspension), it means motor is now under working as command required, polling command needs to be sent to query current status. Reset command needs to be sent after every control command B2=0x44 or 0x49. First send 0x44, then send 0x4a, finally 0x45 to reset.

6- CAN Debug Instructions

(1) CAN Debug Tool: CAN Test as picture 15 (CANTest_Setup_V2.23.exe)

① Send command: Query current motor status



Picture 15

Open CAN debug, interface as picture 15, Click "send" after select the correct baud rate, click "confirm" to below interface, click "Start" then input command to proceed.

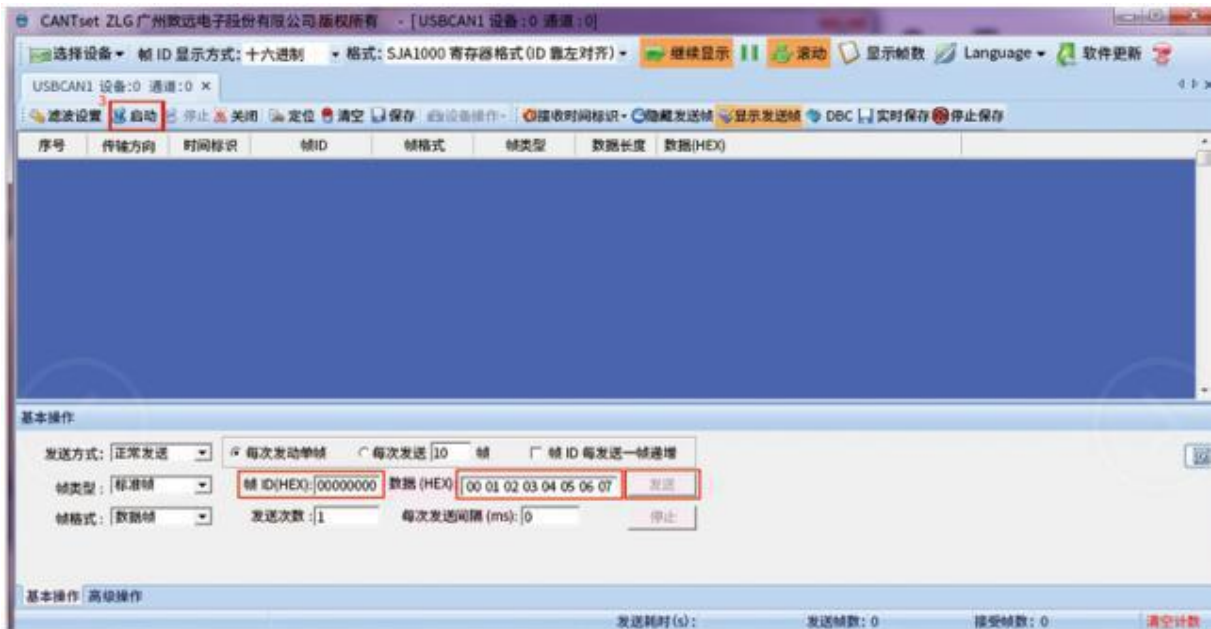

Picture 16

Or, click “confirm and start” then input commands to proceed. Input “Frame ID” (address) and “Data”, click “send” to get received code. For example, input command 0x4a to inquiry motor status, other options no need to change, sent and received command will displayed as picture 17:



Picture 17

(2) CAN communication example

① Send command: Reset

B0	B1	B2	B3	B4	B5	B6	B7
0xCC	0x00	0x45	0x00	0x00	0xDD	0xEE	0x01

Response command

B0	B1	B2	B3	B4	B5	B6	B7
0xCC	0x00	0x00	0x00	0x00	0xDD	0xA9	0x01

Operation result as picture 18:



Picture 18

Received commands B2=00 means device works normally and successfully reset.

Application Instruction

(1) Single-side Rpm-01

Connecting check valves with the two channels of Single-side Rpm-01, liquid was pumped into the syringe from container A by the inlet-only check valve and pumped into container B by the outlet-only check valve.

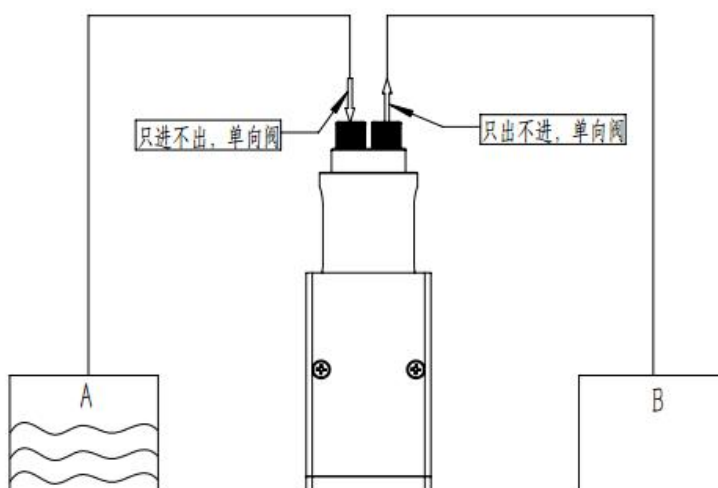

When powered on and press start button, motor drive the internal eccentric, eccentric runs 1 circle to make the piston moving at a stroke (downward then upward) to realize liquid suction and dispensing once, pump keeps circularly working to realize constant liquid transfer like peristaltic pump.

(2) Double-side Rpm-01

Connecting check valves with the two channels of Double-side Rpm-01 and Y or T connectors, liquid was pumped into the syringe from container A by the inlet-only check valve and pumped into container B by the outlet-only check valve.

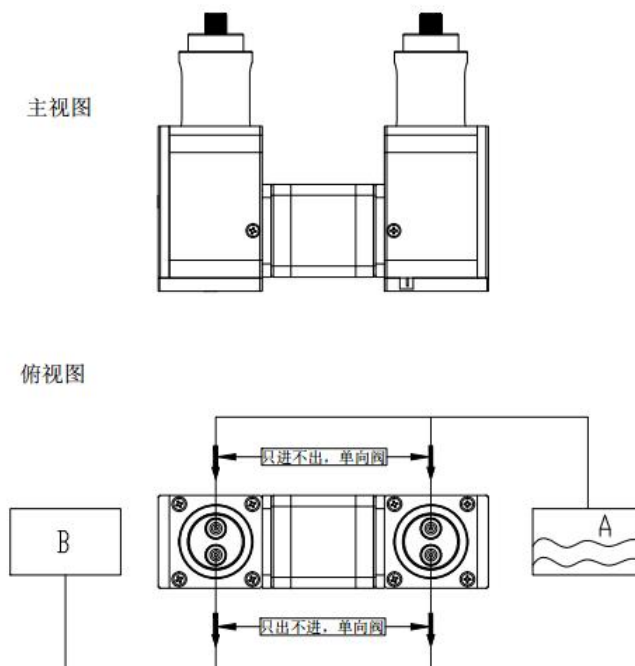

Remark: Under the same syringe specification and same motor speed, liquid volume of double-side syringe pump will be double than single-side syringe pump.

Control Driver (Rpm-01 without driver)

- 1) PWM control driver – MC-20T
- 2) RS232/RS485/CAN control driver – MC-20C



Packing Info.

Carton Size: 26*15.5*18.5CM (single-side Rpm-01) 38*18*20CM (double-side Rpm-01)

G.W.: 2.0KG (single-side Rpm-01) 3.0KG (double-side Rpm-01)



Nanjing Runze Fluid Control Equipment Co.,Ltd
 No.9 Tianxing West Road Dongshan Street Jiangning District
 Nanjing City, Jiangsu Province, China
 Mobile: +86 17366384502
 Email: min.zhu@runzeliuti.com
 Contact: Julie Zhu